

# AR SERIES

AR25



This is a high-resolution, singleturn absolute encoder with a 20 Bit BISS-C interface. The encoder consists of several optical reflectance sensors arranged at an angle of 180 degrees to each other. This allows to

eliminate mechanical errors in the application, such as the runout of the measured shaft, by using subsequent electronics.

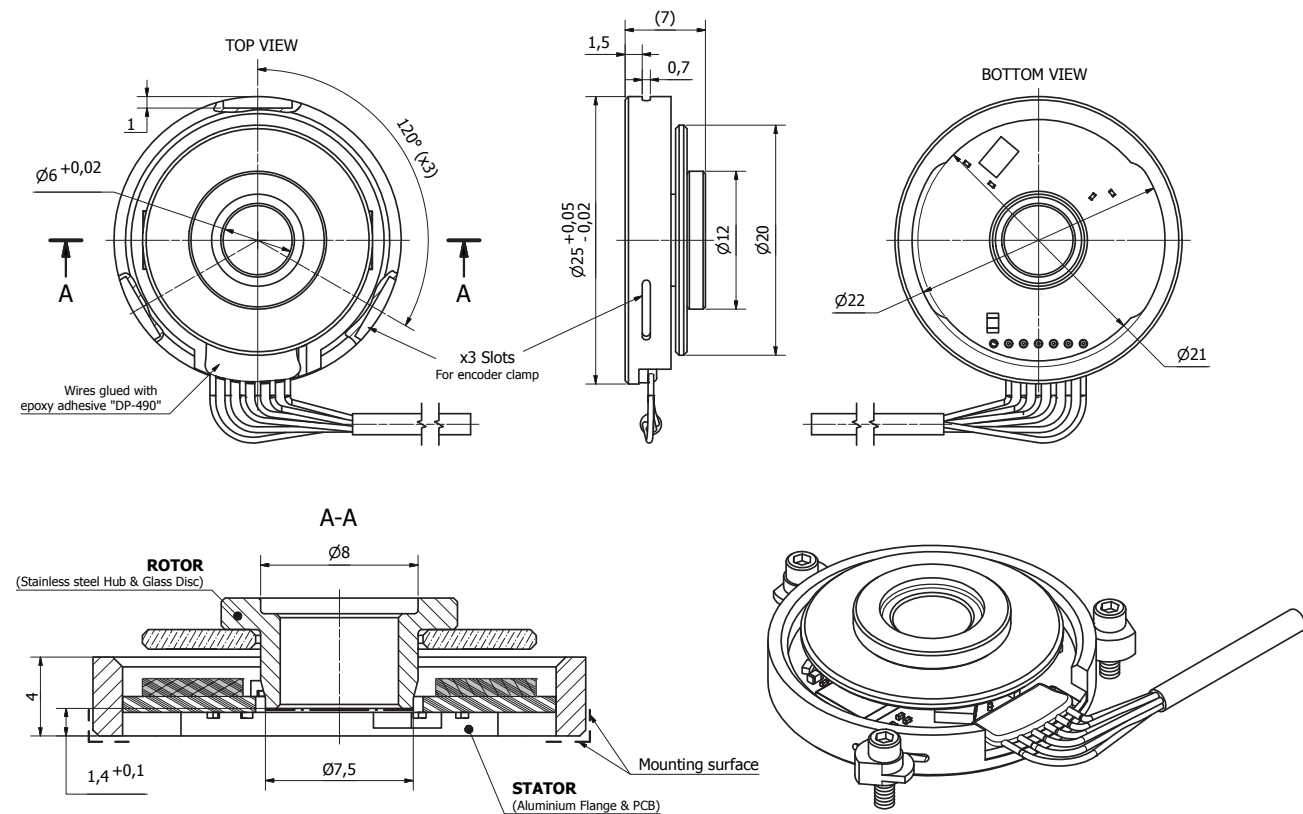

## MECHANICAL DATA

Maximum shaft speed	20000 rpm
Permissible vibration (55 to 2000 Hz)	$\leq 100 \text{ ms}^2$
Permissible shock (11 ms)	$\leq 400 \text{ ms}^2$
Operational shock (11 ms)	$\leq 200 \text{ ms}^2$
Protection (IEC 529)	IP00
Max. weight (without cable)	0.01 kg
Operating temperature	$-40 \dots +70 \text{ }^\circ\text{C}$
Storage temperature	$-40 \dots +100 \text{ }^\circ\text{C}$
Maximum humidity (non-condensing)	98 %

## ELECTRICAL DATA

Accuracy*	$< \pm 10''$
Output code	Binary
Data interface	BiSS C
Supply voltage	$+5V \pm 5\%$
Supply current	80 - 220 mA
Start up time	13 ms
Scan ratio of T	40 - 60 %
Time lag	80 ns
Monoflop time	timeout + $T/2 \text{ } \mu\text{s}$
Rise and fall time	4 - 15 ns

\*Expected at optimum installation, additional deviations due to mounting and inaccuracy of the measured shaft are not taken into account.

## INTERFACE

### DATA TRANSFER BISS-C

DESCRIPTION	DATA
$T_{\text{timeout}}$	0.075 $\mu\text{s}$ - 24 $\mu\text{s}$
Clock frequency	62.4 kHz - 20 MHz

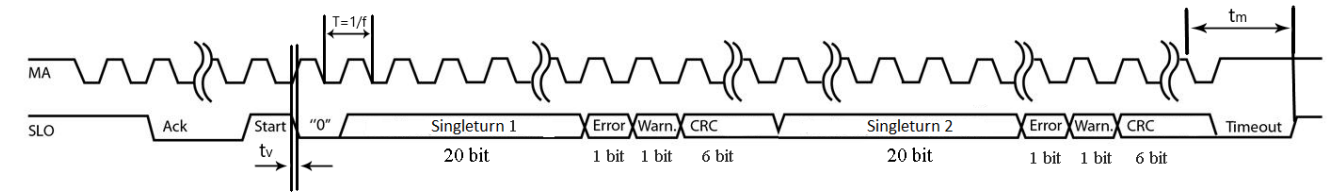

### TYPICAL OPERATING CIRCUIT FOR BISS-C

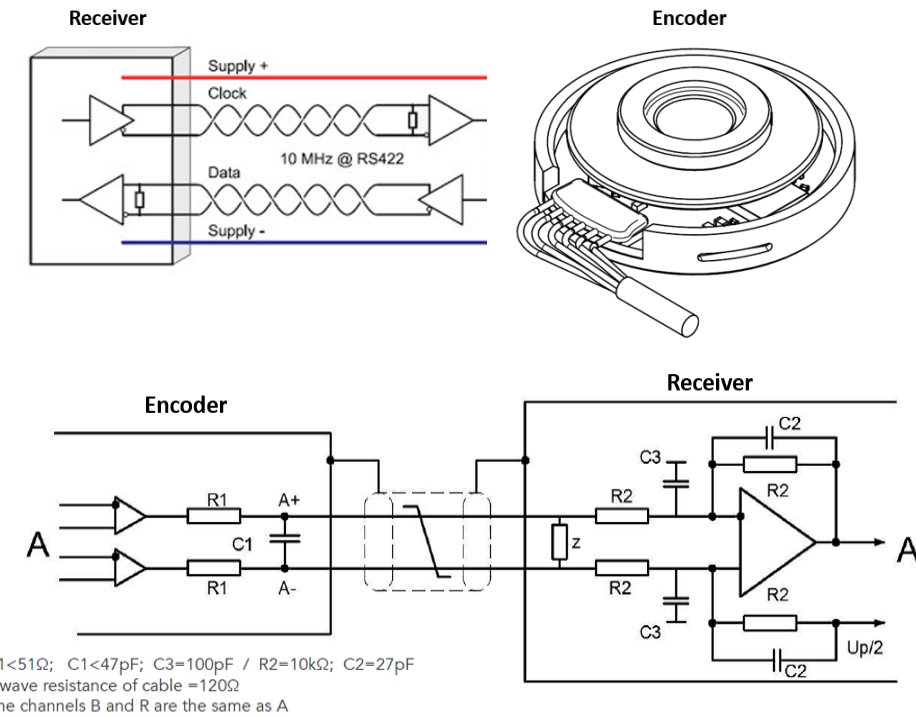

## MOUNTING DIMENSIONS

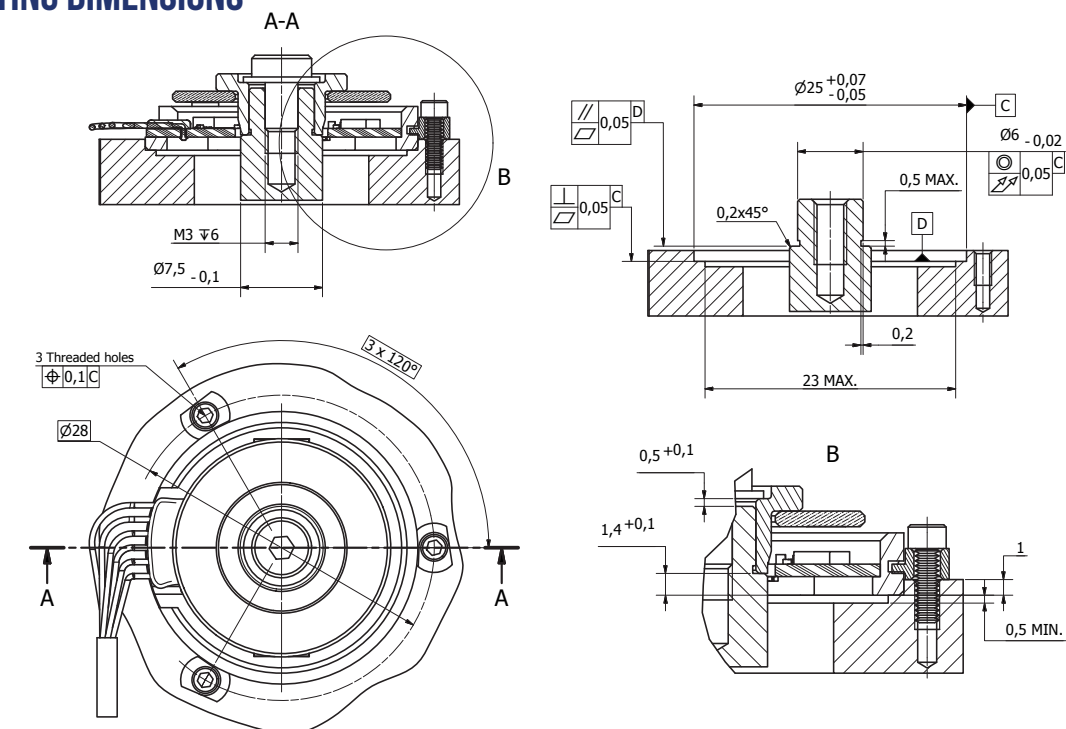

This is just one example of a tailor made encoder kit. For other mechanical, electrical configurations or different interface options please contact us directly: [sales@precizika.com](mailto:sales@precizika.com)