

Magnescale

SPEED X PRECISION

Feedback scale System for Rolling mills

Head
HA705LK Series
Scale
MSS-976R Series
Interpolator
MD50-2N/4N Series



- Major Rolling mill manufacturers around the world adopt this system.
- Proven and reliable digital measuring system for use in metal processing environments.
- Feedback control system can be incorporated into custom built equipment racks.
- 2 and 4 axis interpolator available.
- Magnescale® Technology

Head Scale

HA-705LK MSS-976R

-Excellent vibration resistance and waterproof head, guaranteed high reliability.

Head : HA-705LK

■ Waterproof performance equivalent to IP67.

■ Structure of excellent vibration resistance and shock resistance.

-Resist bad environment of rolling mill by water proof head developed only for it and excellent against harsh environment Magnescale.

-At tests done by our company, it has shock resistance which is 30 to 50G at acceleration and 110G or more at drop test (under our test condition).

■ Capable of extend with the cable only for it.

-Compliable with cable length up to max.150m

-Use material excellent for waterproof and oilproof

Scale rod : MSS-976R

■ Accuracy : $\pm 3\mu\text{m}$

■ Measuring length : 200mm up to 600mm
(Overall length ; 30+ML+30 mm)

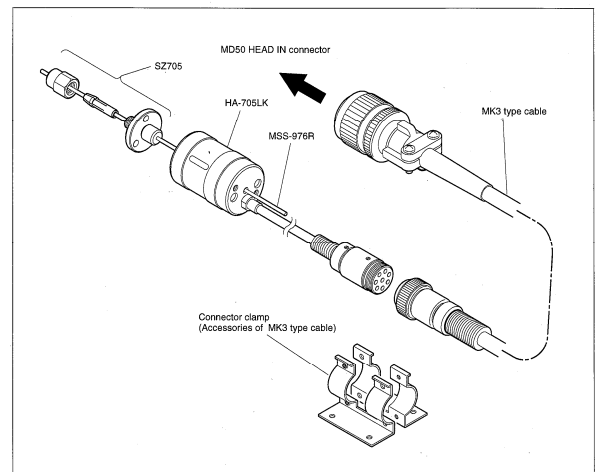

Special connection model	Cable terminal processing, description	L measurement	Special connection model	Cable terminal processing, description	L measurement
Standard	Preparing the cable end	500 $^{+50}_{-10}$	906	Preparing the cable end	1000 $^{+50}_{-10}$
901	Including connector	560 $^{+50}_{-10}$	907	Preparing the cable end	1500 $^{+50}_{-20}$
902	Vacant (combined with 907)	1500 $^{+50}_{-20}$	908	Not available	
903	Including connector	1000 $^{+50}_{-20}$	909	Not available	
904	Vacant (combined with 906)	1000 $^{+50}_{-10}$	910	Including connector	1500 $^{+50}_{-30}$
905	Including connector	2540 $^{+50}_{-30}$	911	Not available	

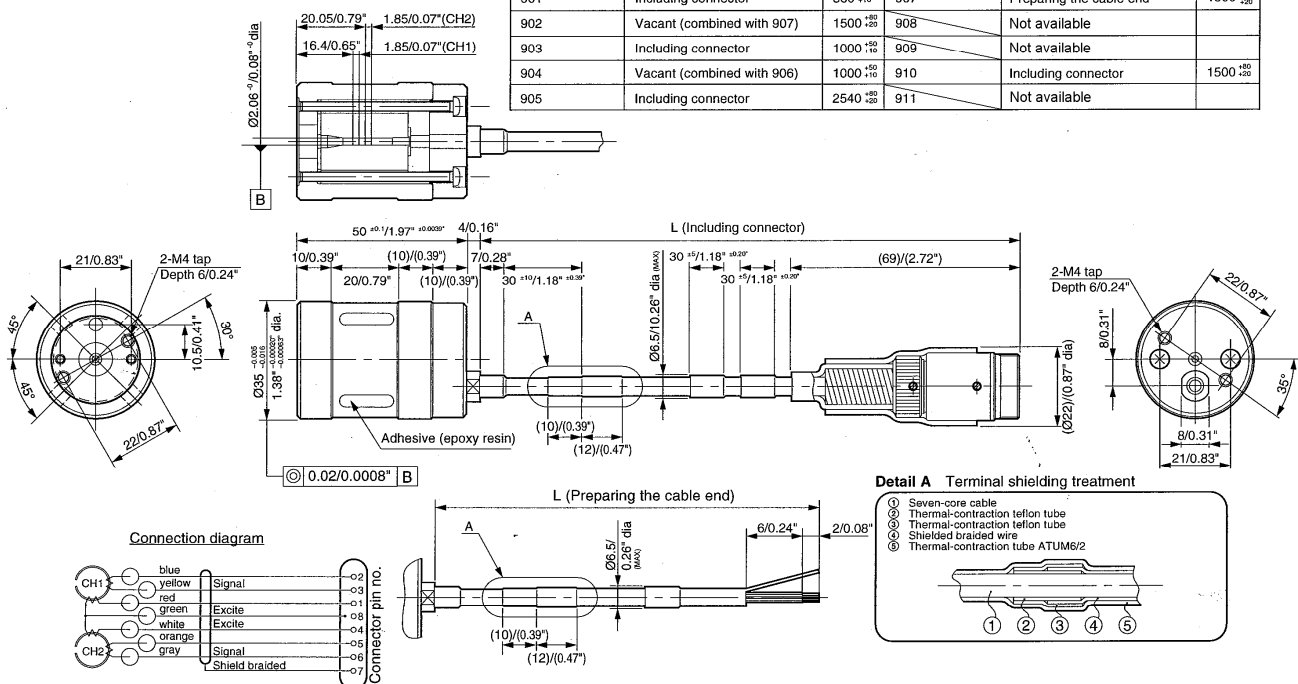

Insulation resistance and insulation yield strength

There should be DC 250 V over at least 50 m and a one-minute leakage current of 5 mA or less at AC250 V between the coils, coil and head unit, head unit and housing, and shield and head unit.

Note

The connection section of the thermal-contraction tube ATUM6/2 for the cable does not have a designated location. (This is because the length varies depending on the contraction state.)

Interpolator

MD50-2N/4N

-High reliability and many functions, it can comply with a variety of equipments.



- With max. response speed 100m/min, comply with shocks of rolled material.
- Comply with world-wide power source : AC100 to 240V
- Selectable from 5 kinds of output pulse resolution and 9 kinds of output pulse width
-Select resolution from 0.5 to 10 μ m, output pulse width from 0.1 to 4.0 μ s.
- Can be selected A/B signal or Up/Down signal.

- Selectable of setting 2 kinds and 6ways of alarm output adjusting to user's usages
-Alarm output can be detected with signal output to controller and with lump of main unit lighting. This makes it monitor deteriorating with age, and it becomes effective means of maintenance.
- Standard equipping A/B signal for monitor or Up/Down signal output.
-Possible to make A/B signal output as a monitor for maintenance, except signal output to control device.
- Body configuration of capable of inputting up to max.4 axes.

-Capable of easy maintenance because of adopting card type detector board. And, even if only 1 axis is out of order, it can do with the change of only the board, because each axis is independent.

AB Signal

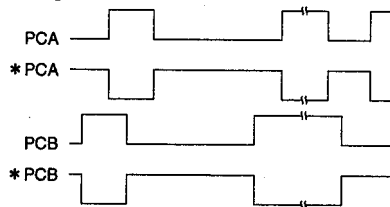

Up / Down Signal

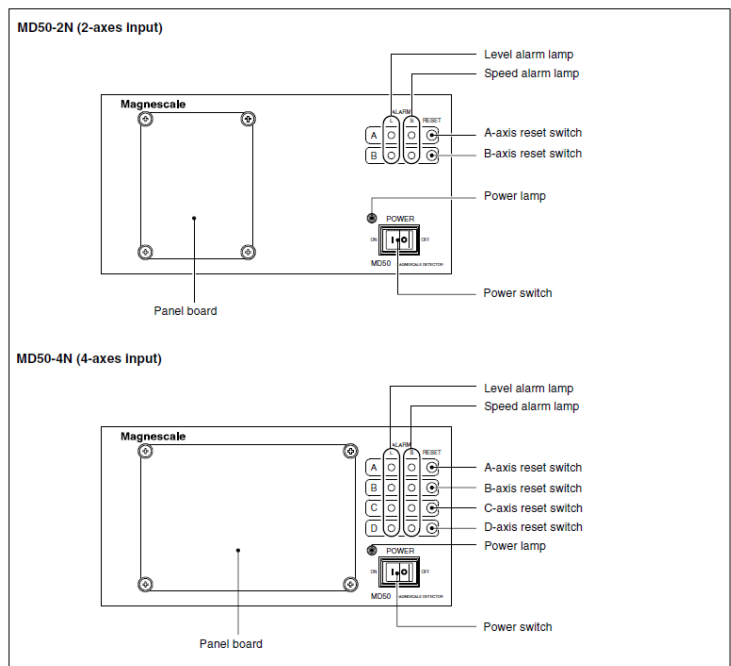
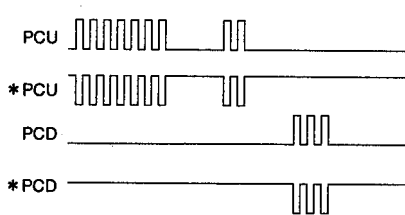

■ Main specifications

Model name	MD50-2N	MD50-4N
Input axes	2 axes	4 axes
Scales to be connected	HA-705LK	
Resolutions	0.5, 1, 2, 5, 10µm (Selectable)	
Output pulse width	0.1, 0.2, 0.4, 0.8, 1.0, 1.6, 2.0, 3.2, 4.0µs (Selectable)	
Max. response speed	100m/min (Depending on the resolution and output pulse width)	
Main output signal	A/B signal or Up/Down signal (Selectable), Line driver output (Equivalent to SN75183)	
Sub output signal	A/B signal or Up/Down signal (Selectable), Line driver output (Equivalent to SN75183)	
Synchronous signal	Output for the stable reception of A/B or Up/Down signals.	
Alarm functions	Level alarm : Hi-level signal is output when the scale signal drops be 1.4Vp-p (or 0.6Vp-p) or less. Speed alarm : Hi-level signal is output when the maximum response speed of scale is exceeded.	
Alarm reset functions	Manual reset operation : Push the RESET switch on the front panel. Reset operation by external signal : Apply a DC voltage between 2 input terminal.	
Cable length	Max. 150m (Option : Extension cable : MK3 -30, -50, -100, -120, -135, -150)	
Operating temperature	0 to 40°C	
Storage temperature	-20 to 60°C	
Power consumption	Max. 70 VA	
Input power voltage	100 to 230V±10% 50/60Hz	
Dimensions	260(W) x 359.5(D) x 141.5(H) mm	
Mass	Approx. 5.8Kg	Approx. 7.0Kg
Applicable standards	UL3101-1 , FCC Part 15, Subpart B, Class A EMC Directive EN55011 Group 1, Class A EN50082-2 , Low Voltage Directive EN61010-1	

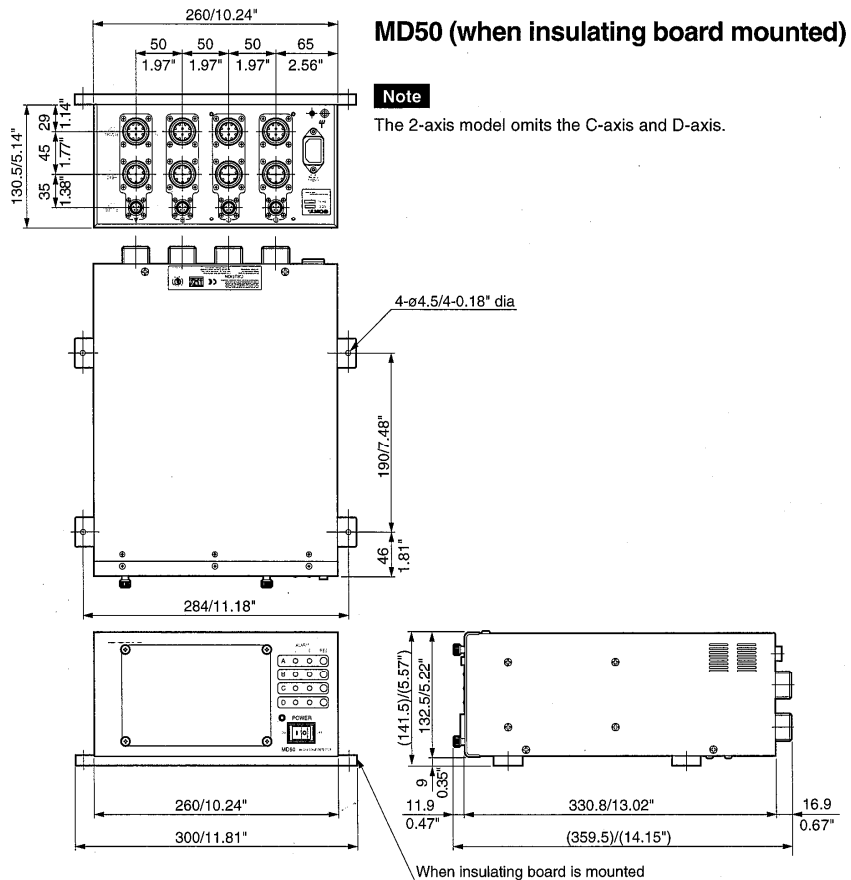

Innovative Measurement Technology Ltd

Unit 3E Vinnetrow Business Park, Vinnetrow Road, Chichester, West Sussex,
PO20 1QH, United Kingdom.

TEL. +44 (0) 1243 942010 E-mail. sales@imeasure.co.uk
Web. www.imeasure.co.uk

*Designs and appearances are subject to change without prior notice.

INNOVATIVE
MEASUREMENT
TECHNOLOGY LTD.

